

# **Adjustable Turbocharger**

**Design and Function**

**Self-Study Programme**



**Service Department**

If the water level in the mill stream drops, the current will no longer be sufficient to turn the water wheel.

If the miller still wants to grind corn, then he has to narrow the stream of water.

To the miller, the stream is as important as the exhaust gas energy is to the turbocharger.

By using adjustable vanes, the response of the adjustable turbocharger at low engine speeds is quick.

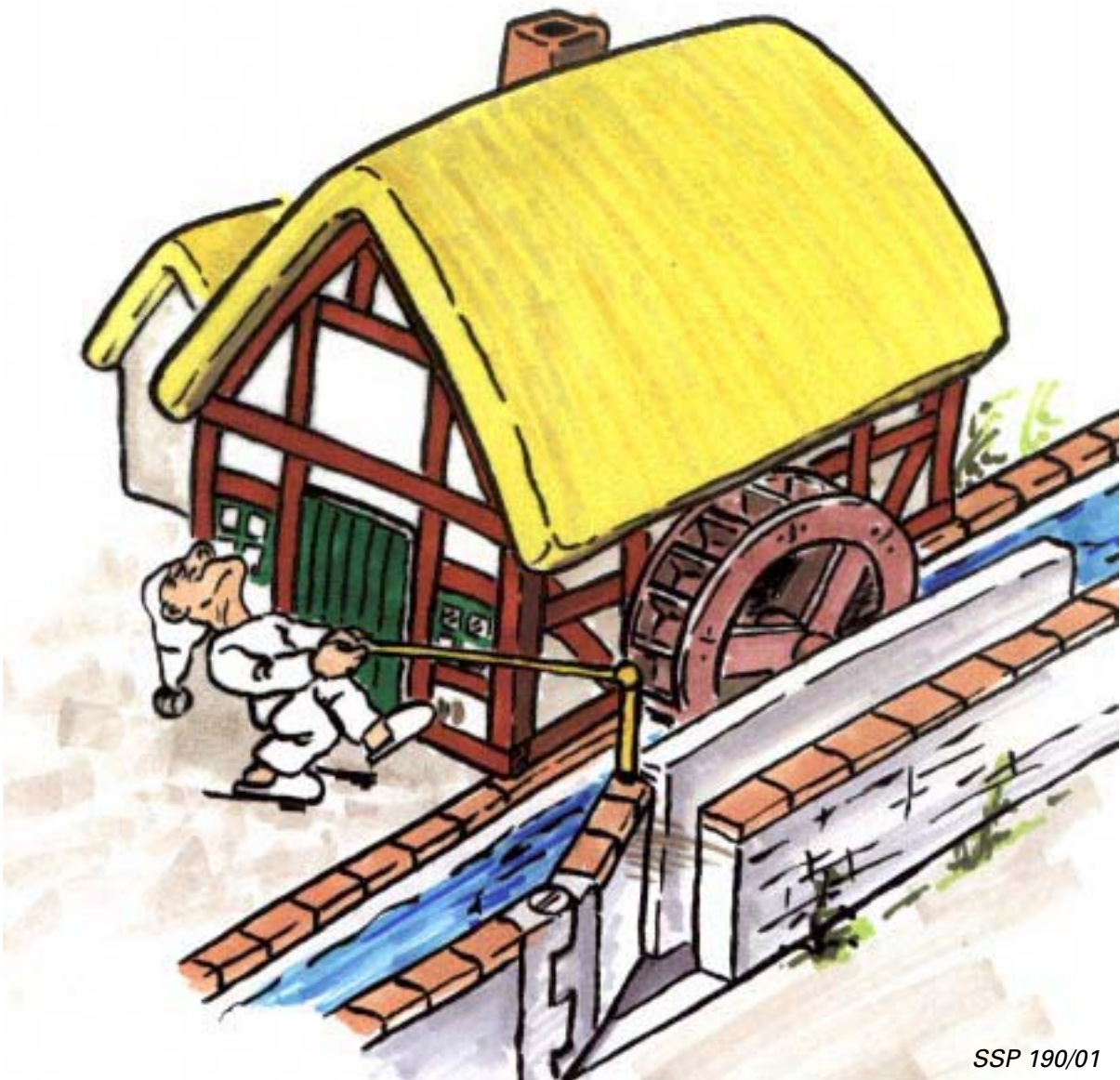

SSP 190/01

	<b>Page</b>
<b>Fundamental principles</b> _____	<b>04</b>
<b>Design and function</b> _____	<b>06</b>
<b>Mechanics</b> _____	<b>11</b>
<b>Function chart</b> _____	<b>16</b>
<b>System overview</b> _____	<b>18</b>
<b>Engine control unit</b> _____	<b>19</b>
<b>Sensors</b> _____	<b>20</b>
<b>Actuators</b> _____	<b>24</b>
<b>Self-diagnosis</b> _____	<b>26</b>
<b>Functional diagram</b> _____	<b>29</b>



**Important! / Note!**



**New!**

The Self Study Programme is not a Workshop Manual!  
Please refer to the Service Literature which contains all the relevant inspection, adjustment and repair instructions.

# Fundamental principles

## The basic principle of an exhaust gas turbocharger

An exhaust gas turbocharger is used to achieve high torques, and thus higher engine outputs.

This effect is achieved by compressing the intake air. The higher intake air density allows a larger volume of air, and therefore more oxygen, to enter the combustion chamber during each intake cycle. The larger oxygen supply boosts the efficiency of the combustion process.

The exhaust gas of an engine contains both thermal and kinetic energy. These energies are utilised to drive the exhaust gas turbine of the turbocharger.

The exhaust gas loses some of its energy and cools down as a result.

The exhaust gas turbine drives the compressor which in turn compresses the intake air, heating it up and thus reducing its density. The intake air is cooled down again in the air intercooler, thereby increasing its density.

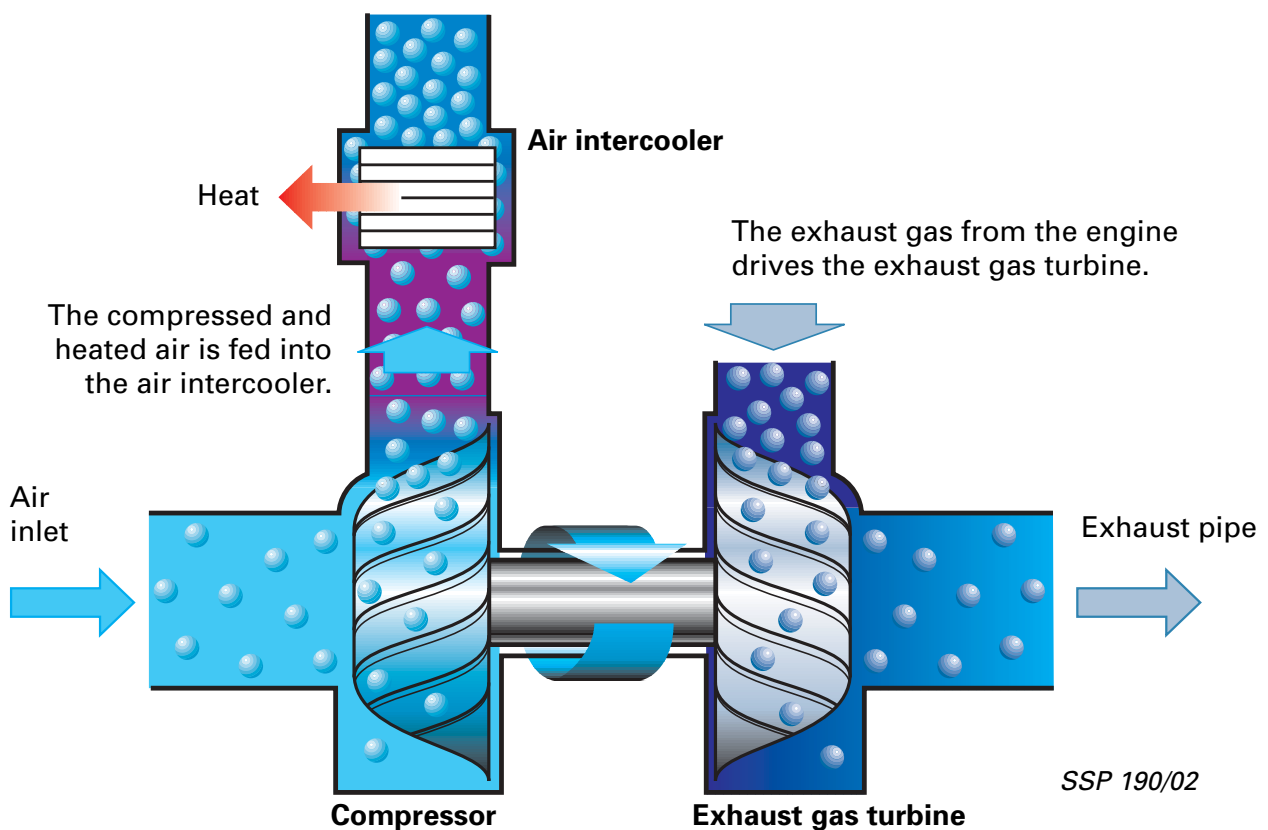

The compressor compresses the intake air.

The exhaust gas turbine drives the compressor.

## The exhaust gas turbocharger fitted with a by-pass

A turbocharger has two sets of problems:

- The turbine speed at the top end of the speed range is high and the air is compressed more than is necessary.
- At the bottom end of the speed range, the exhaust gas turbine does not reach the required speed. The air is not compressed sufficiently and the engine is unable to deliver the desired power output (turbo lag).

It was decided to make a compromise regarding the design of the exhaust gas turbocharger fitted with a by-pass.

At the top end of the speed range, a partial exhaust gas flow bypasses the turbocharger, thus ensuring that the optimum air compression ratio is not exceeded and that the engine delivers its full power output.

However, this system is ineffectual at the lower end of the speed range.

The by-pass is opened or closed by means of a pressure box.

### Turbocharger with by-pass

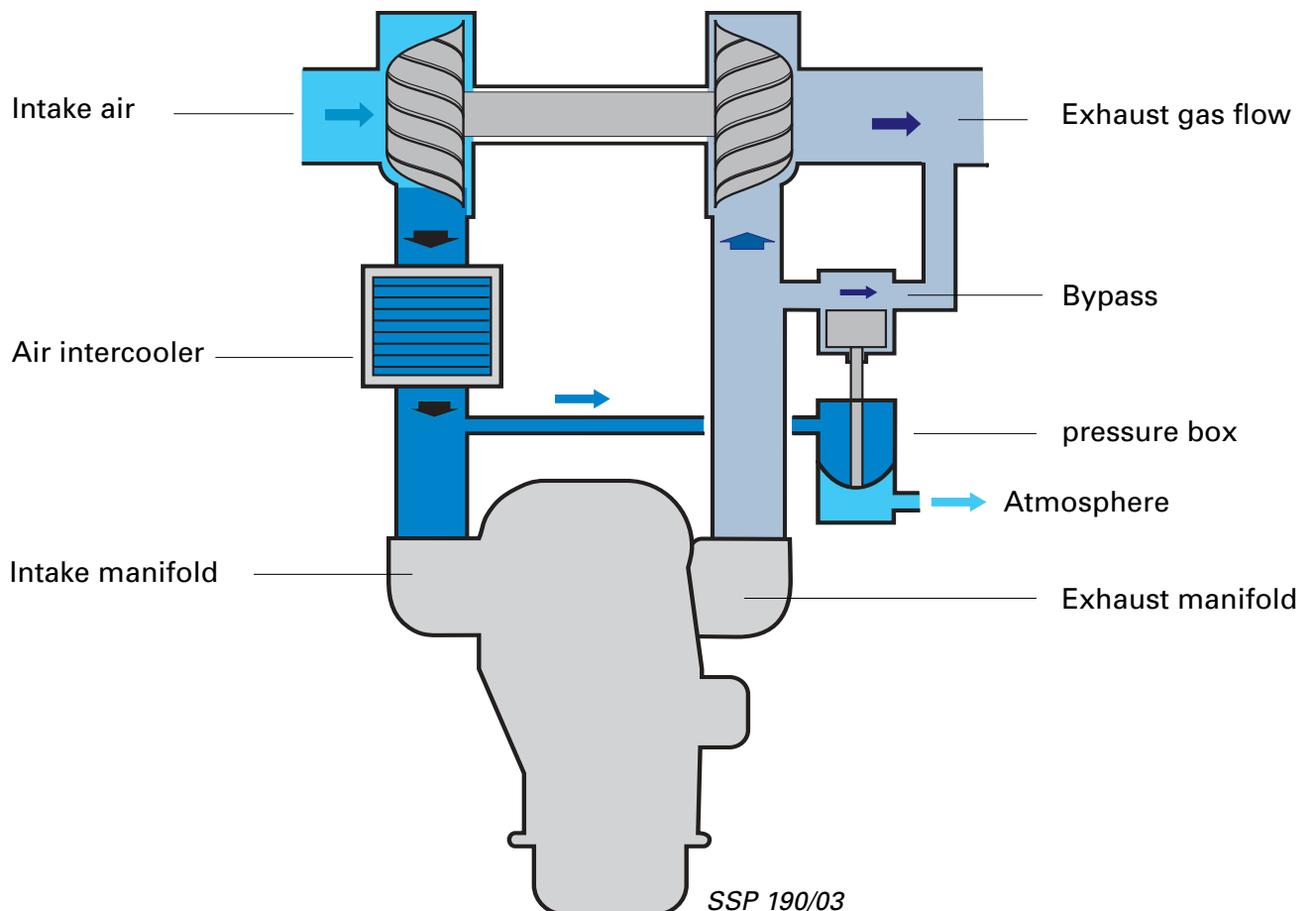

# Design and function

## The design

The turbocharger in the exhaust gas turbine uses adjustable vanes instead of the by-pass. The adjustable vanes control the exhaust gas flow acting on the turbine wheel. The adjusting vanes are moved by means of a low-pressure box.

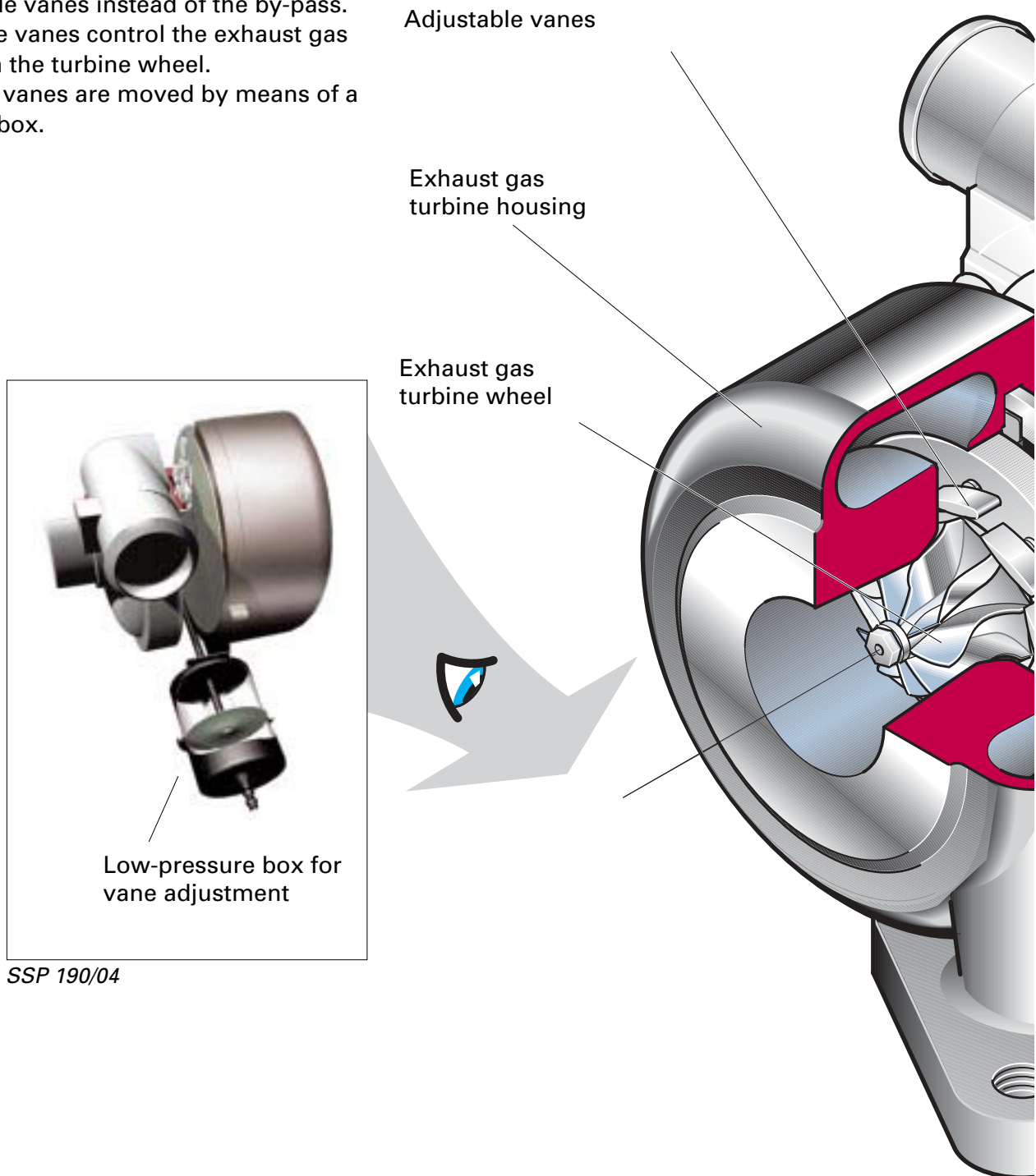

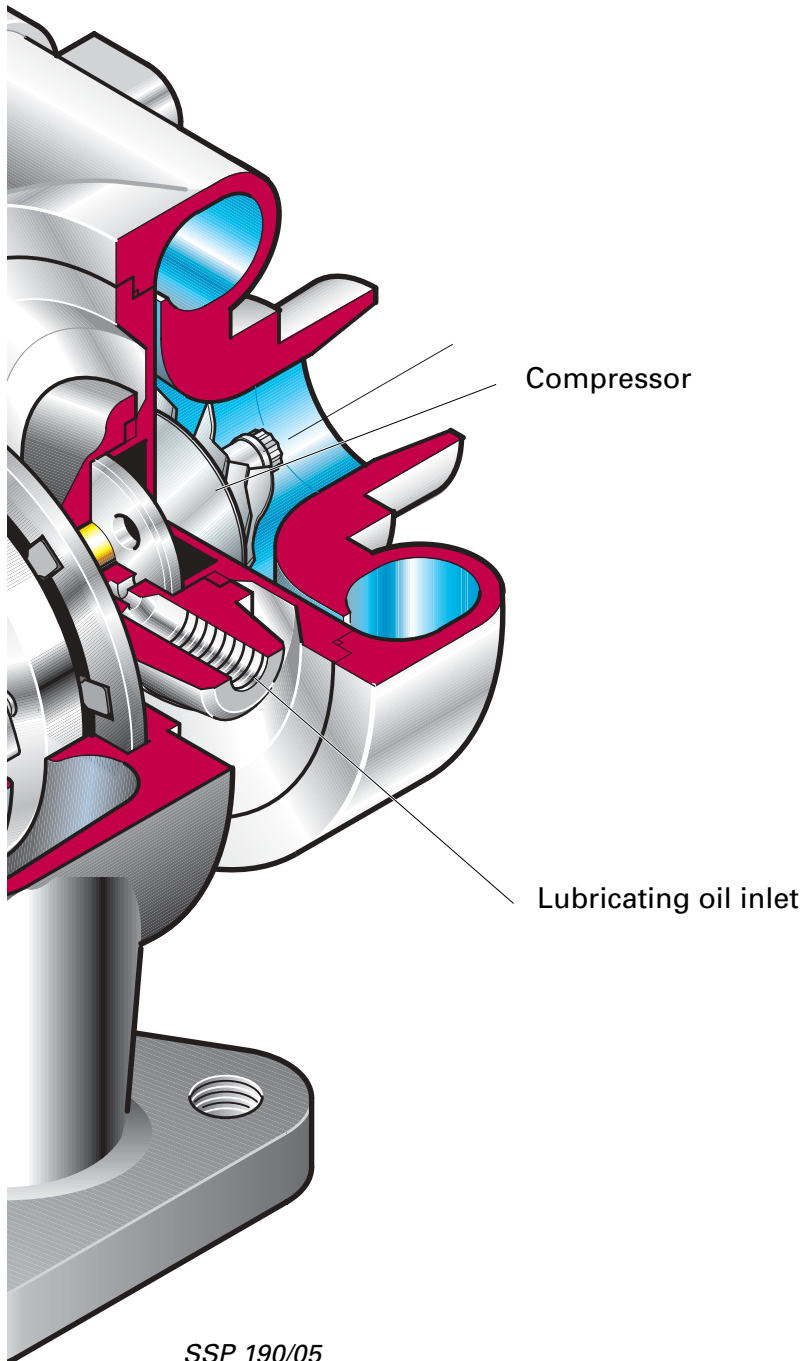

### Advantages

- High engine output is available at the bottom end of the speed range since the exhaust gas flow is regulated by the adjustable vanes.
- The lower exhaust gas backpressure in the turbine reduces fuel consumption at the top end of the speed range and also improves bottom-end power output.
- Exhaust gas emissions decrease because an optimum charge pressure, and therefore also improved combustion, is attained across the full speed range.

SSP 190/05



# Design and function

## The design

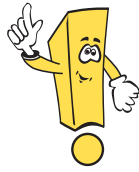

The adjustable turbocharger, in contrast to the exhaust gas turbocharger fitted with a by-pass, produces the necessary compression not only at the top end of the speed range but also across the full speed range. This is made possible by feeding the exhaust gas flow into the turbine wheel via adjustable vanes.

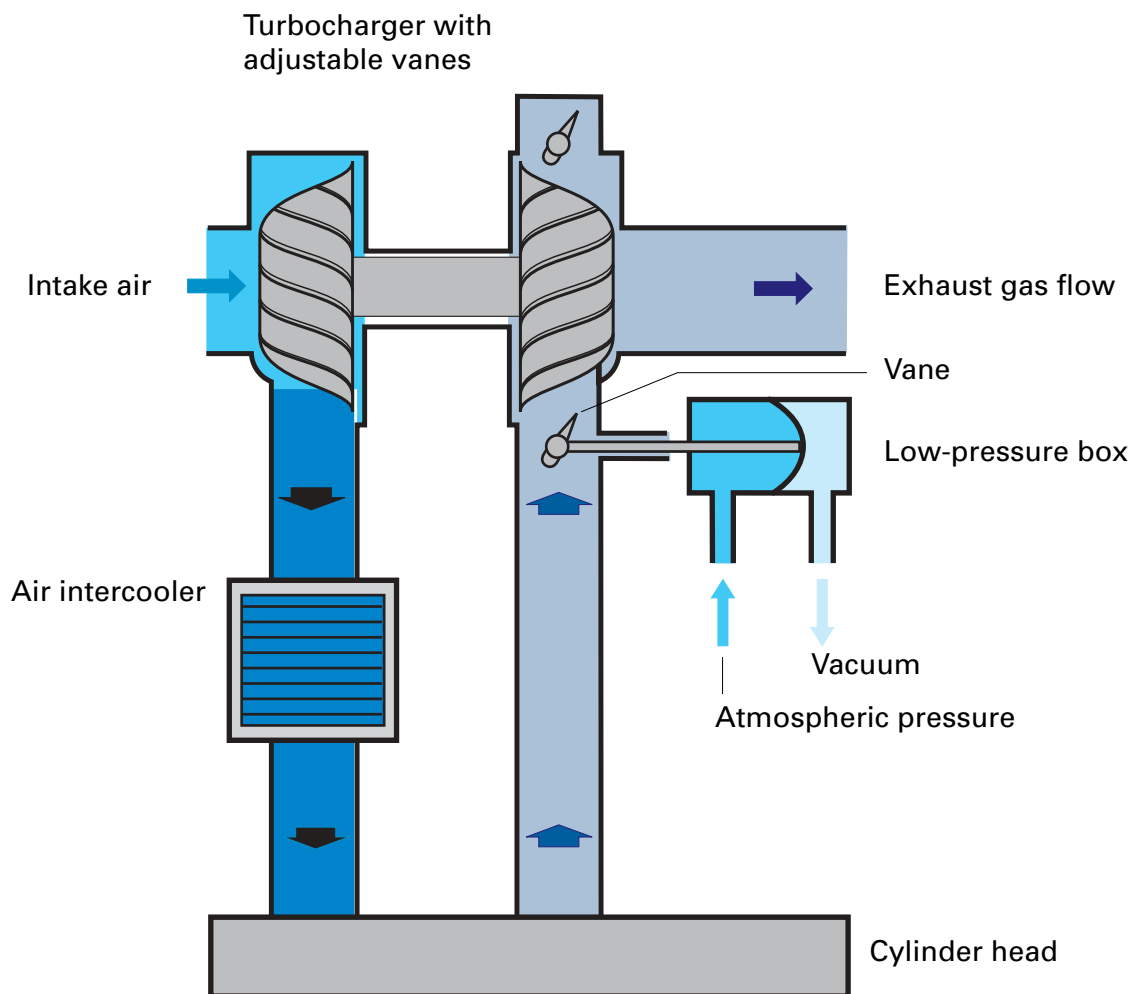

SSP 190/06



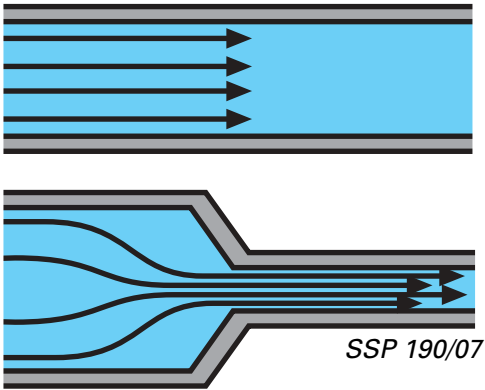

A gas must flow through a narrowed pipe more quickly than through a pipe without a restriction, provided that the pressure in the two pipes is equal.

This fundamental physical principle is applied to the constant-output exhaust gas turbo-charger.

**Low engine speed and high charge pressure are required**

The cross-section of the exhaust gas flow is narrowed upstream of the turbine wheel by means of vanes.

Since the exhaust gas is forced to pass through the restricted cross-section more quickly, the turbine wheel rotates faster.

The high turbine speed at low engine speed generates the required charge pressure. The exhaust gas backpressure is high.

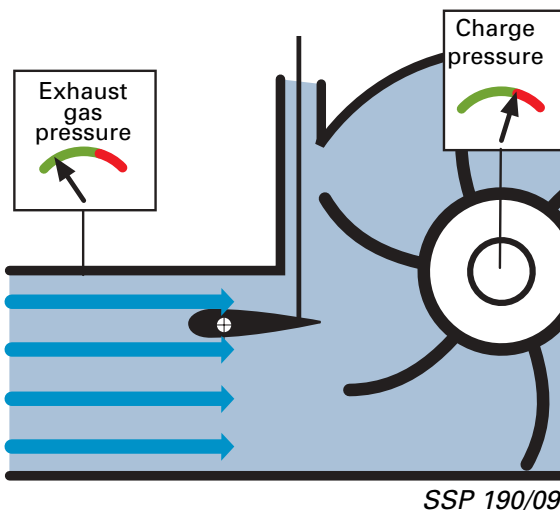
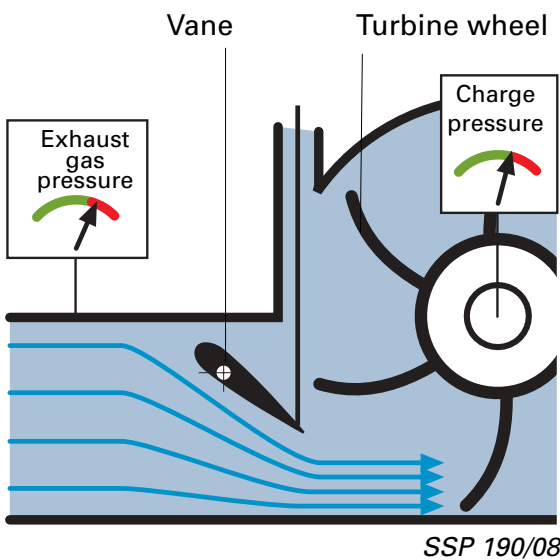

**High engine speed**

The turbocharger cross-section is adapted to the exhaust gas flow.

In contrast to the by-pass, the entire exhaust gas flow can be fed through the turbine in this way.

The vanes free a larger inlet cross-section, thereby ensuring that the required charge pressure is not exceeded.

The exhaust gas backpressure drops.

# Test your knowledge

1. Label the components shown in the illustration below.

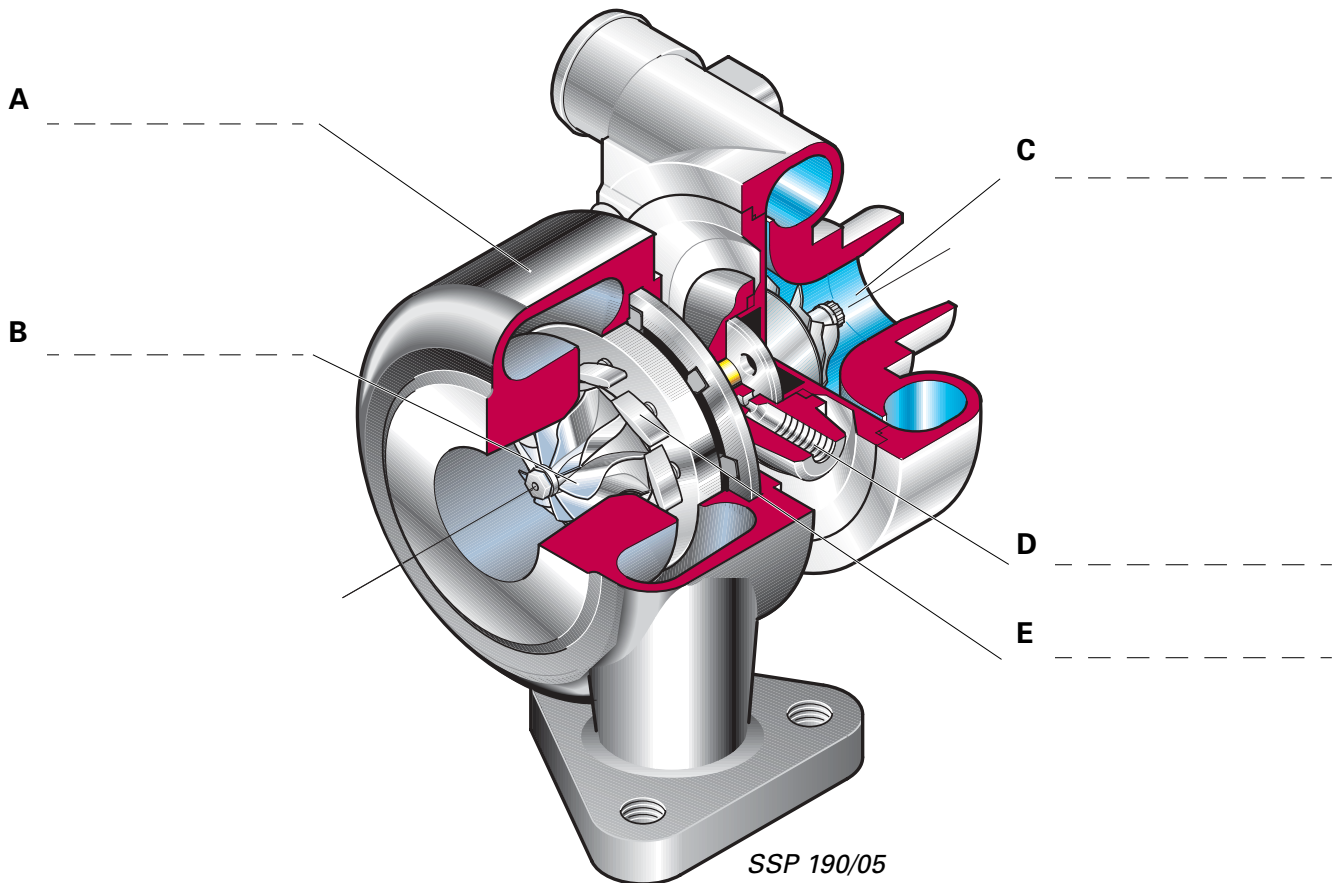

2. Complete the following sentence:

The \_\_\_\_\_ of the exhaust gas turbine is narrowed or released ahead of the turbine  
\_\_\_\_\_ wheel by means of.

## Adjusting the vanes

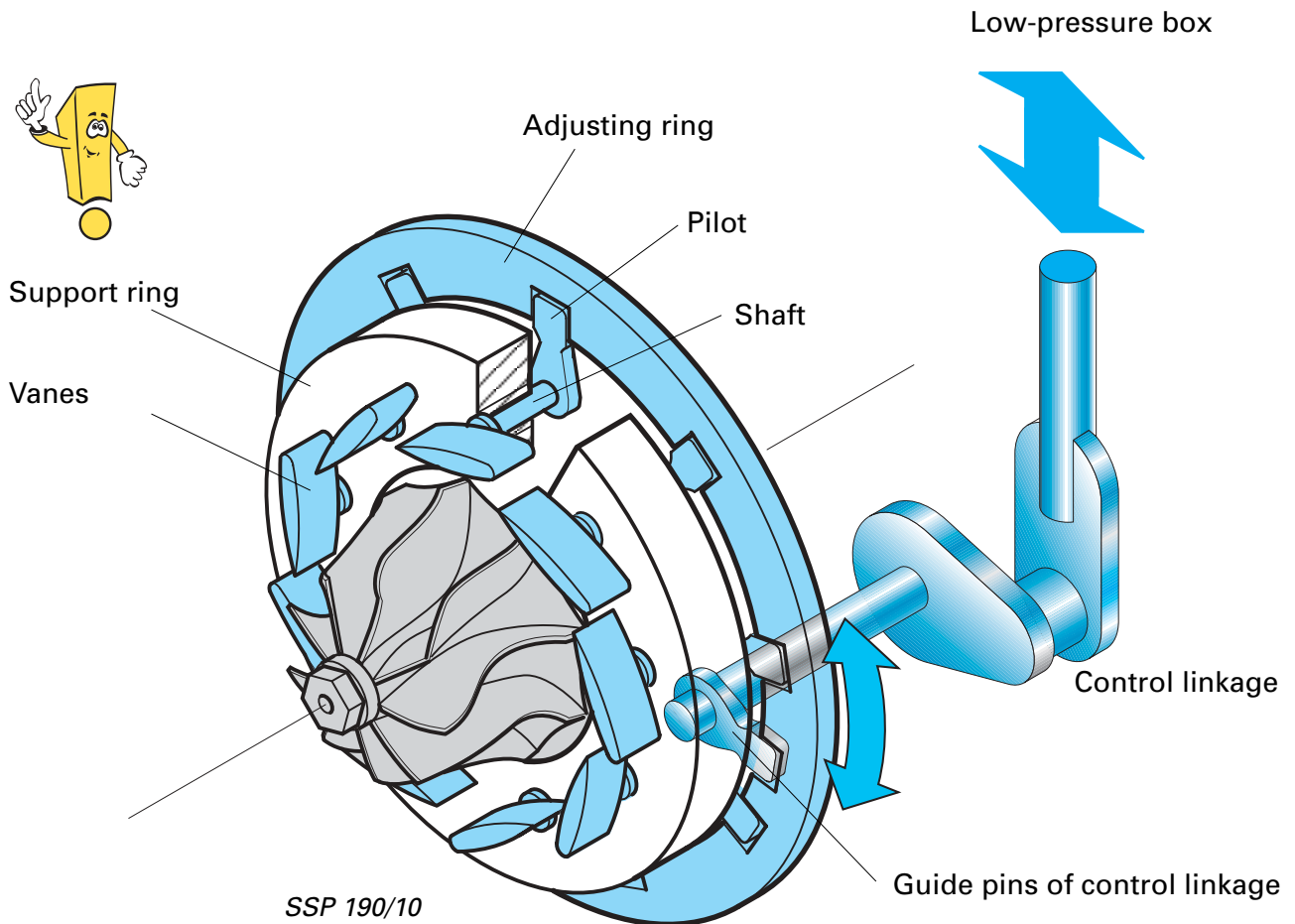

Fit the vanes together with their shafts onto a supporting ring.  
There is a guide pin which engages in an adjusting ring at the back of the supporting ring of the vane shafts.  
All vanes can thus be rotated at the same rate and simultaneously via the adjusting ring.

The adjusting ring is moved by the low-pressure box by means of the guide pin of the control linkage.

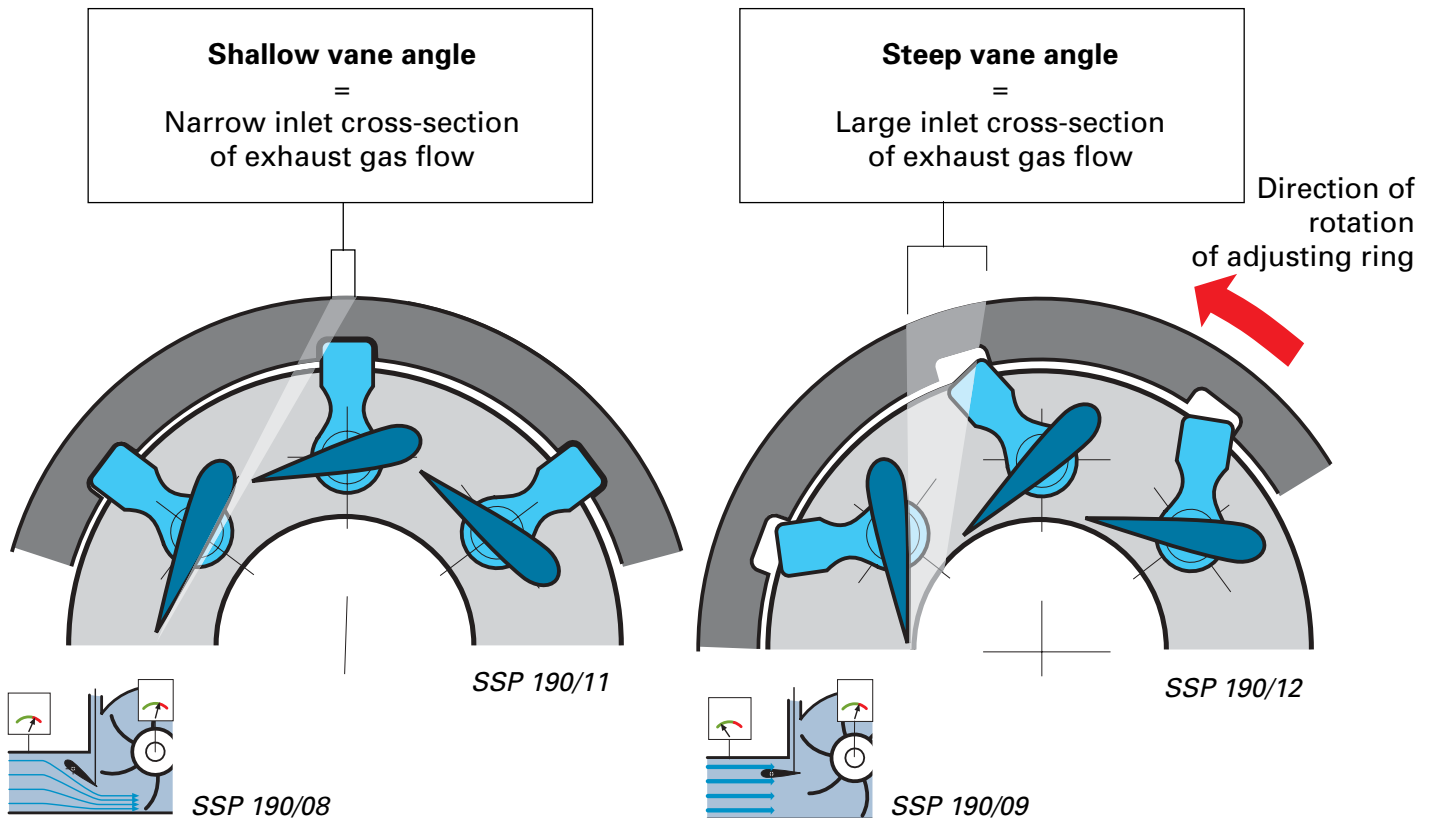

To allow a quick build-up of charge pressure at low speed and under full load, the vanes are set to a narrow inlet cross-section.

The effect of the restriction is to speed up the exhaust gas flow, thus increasing turbine speed.

The vanes are set at a steeper angle with increasing exhaust gas flow rate or if a lower charge pressure is required.

The inlet cross-section is enlarged.

As a result, the charge pressure and the turbine output remain virtually constant.

The maximum angle of the vanes, and therefore also the largest possible inlet cross-section, is simultaneously the vane angle used in emergency operation.

## The N 75 solenoid valve and the low-pressure box for vane adjustment

### Vacuum control for flat vane angle adjustment

The engine control unit controls the N 75 solenoid valve for vacuum supply. The maximum vacuum can, as a result, act on the low-pressure box.

The vanes are adjusted at a shallow angle. This vane position allows the fastest possible maximum charge pressure build-up.

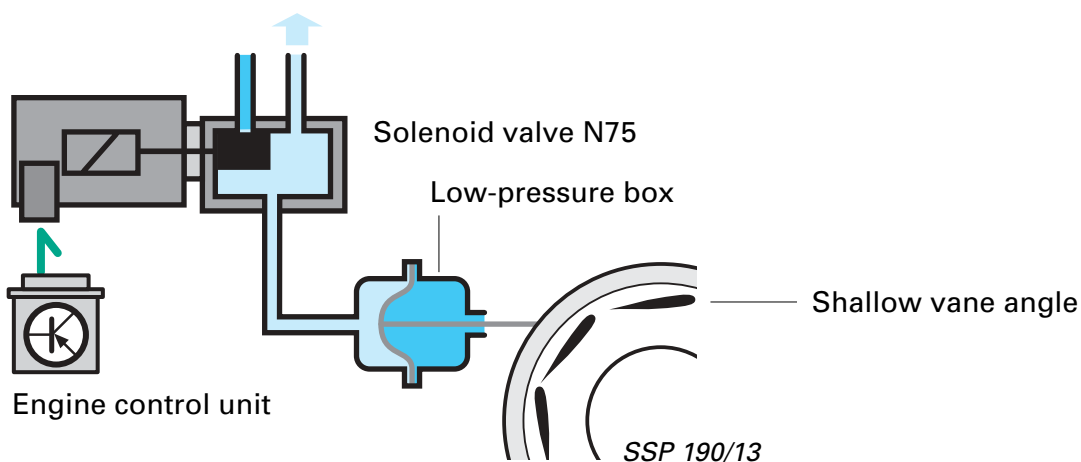

### Vacuum control for steep vane angle adjustment

The solenoid valve is currentless. Atmospheric pressure is fed into the low-pressure box.

The vanes are adjusted at a steep angle. This position is also the adjustment used in emergency operation.

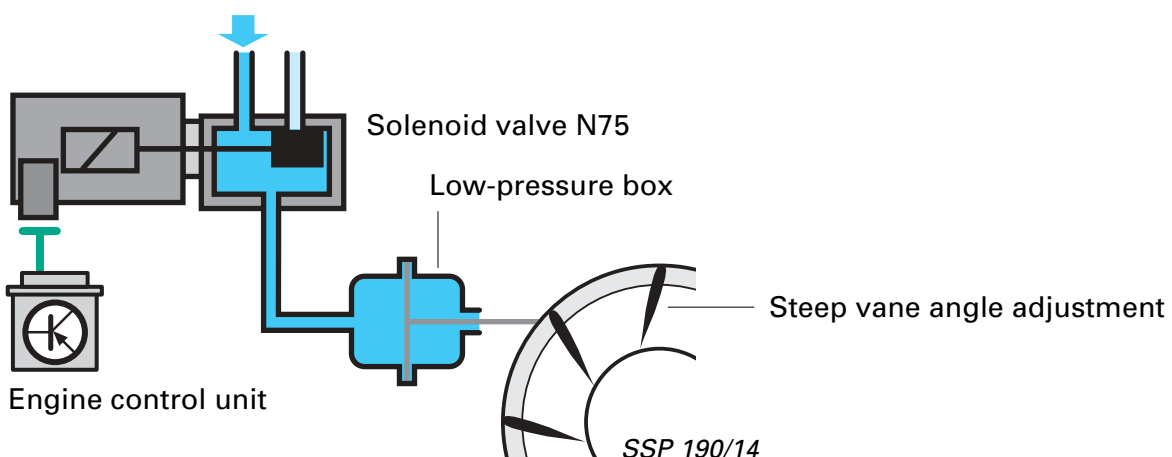

## Solenoid valve N 75 and the low-pressure box for vane adjustment

### Vacuum control for intermediate stages of vane adjustment

More or less power must be available to the engine to cater for momentary driving conditions. Therefore, the turbocharger must deliver the optimum charge pressure.

The solenoid valve is driven in such a way that the vacuum level is adjusted to between atmospheric pressure and the maximum possible vacuum.

This vacuum corresponds to the optimum vane angle adjustment for these speed and load ranges.

The engine control unit can thus respond immediately to changing driving conditions in a continuous control process. It continuously adapts the vane angle adjustment to the desired charge pressure.

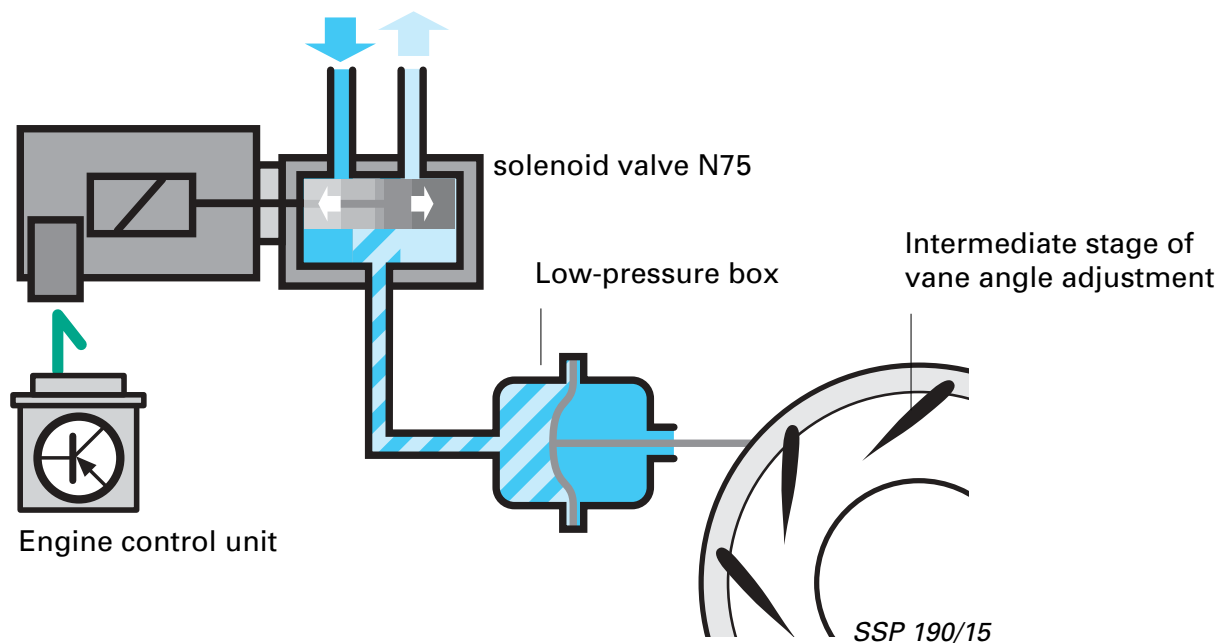

# Test your knowledge

1. What effects does the adjustable turbocharger have?

- A  High bottom-end torque.
- B  Lower fuel consumption at the top end of the speed range.
- C  A low charge pressure at low speeds
- D  Higher exhaust gas backpressures at high speeds

2. Draw the position of the diaphragm in the low-pressure boxes.

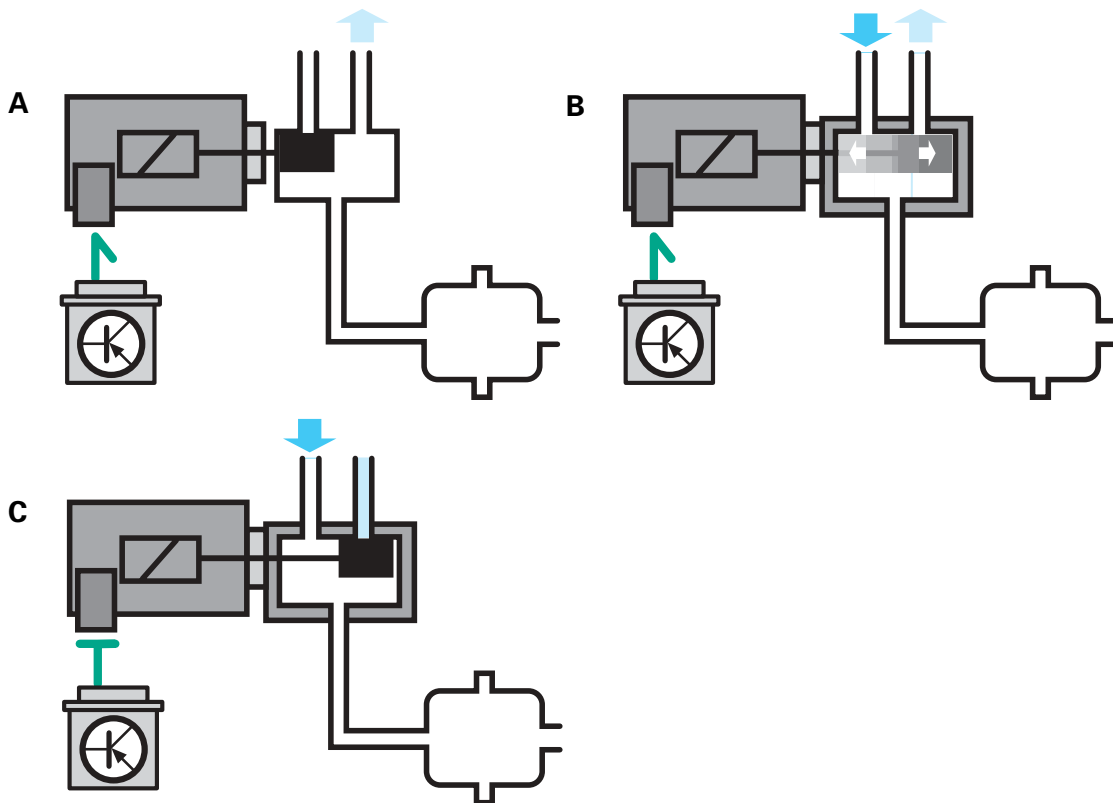

SSP 190/19



# Function chart

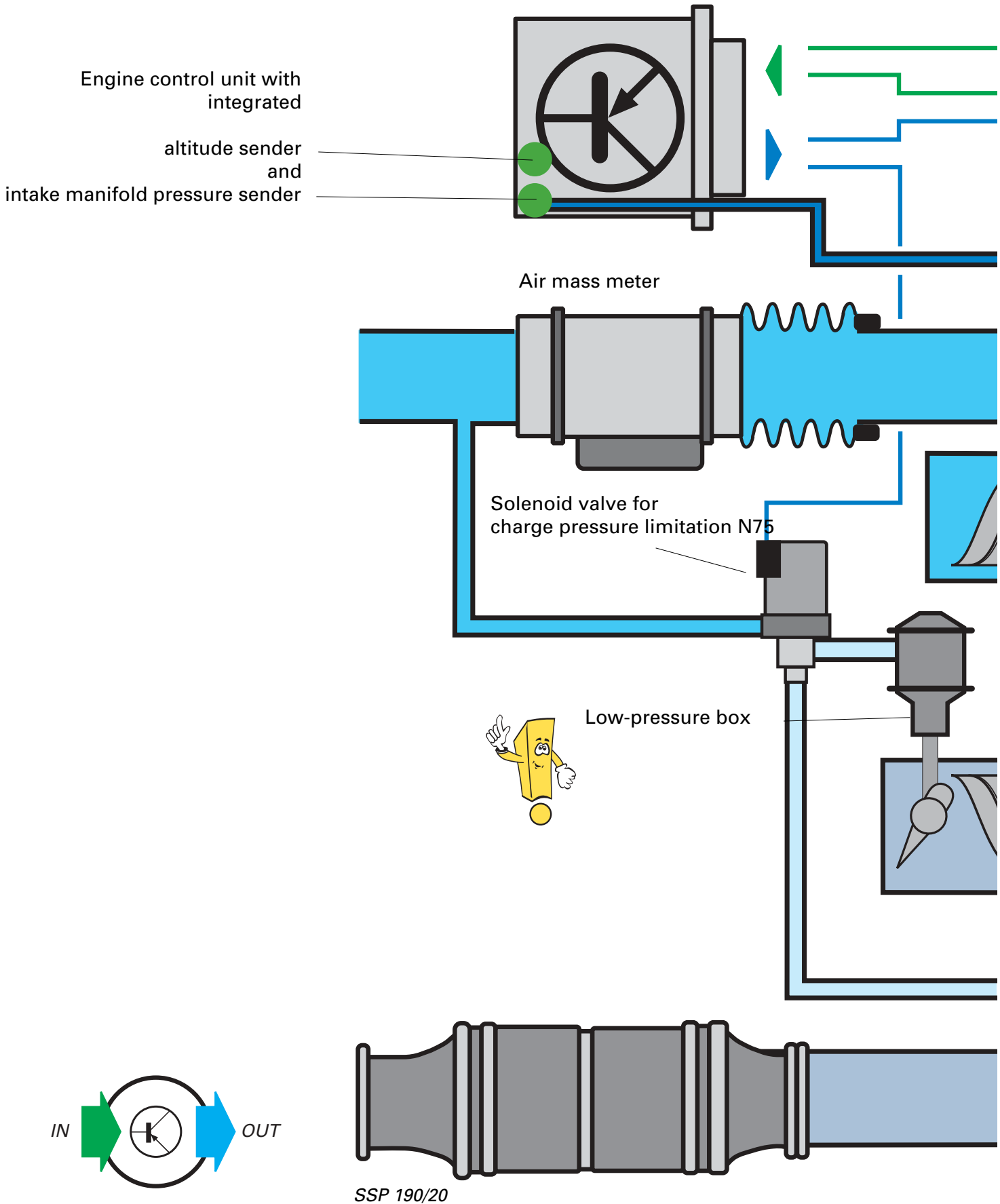

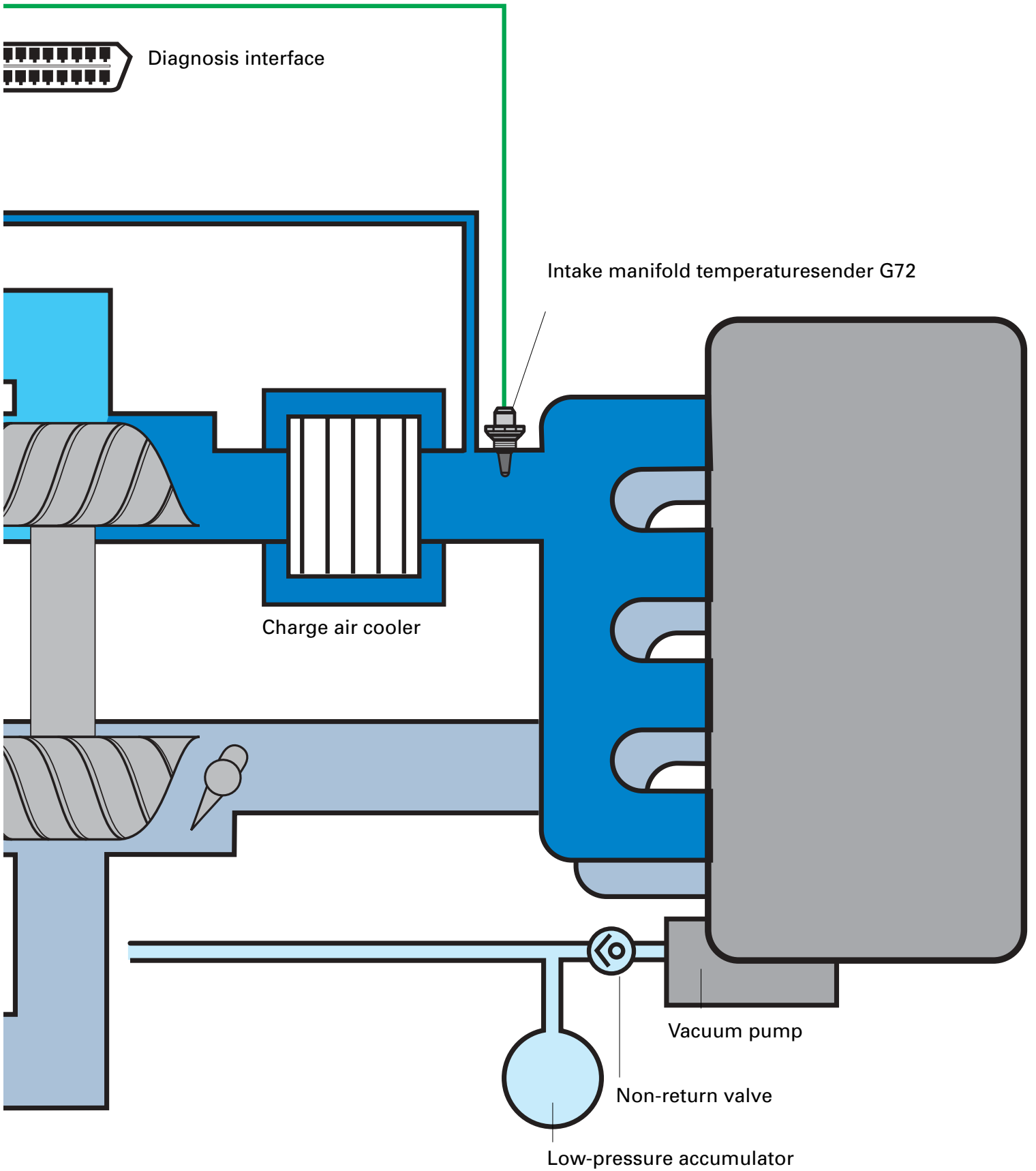

# System overview

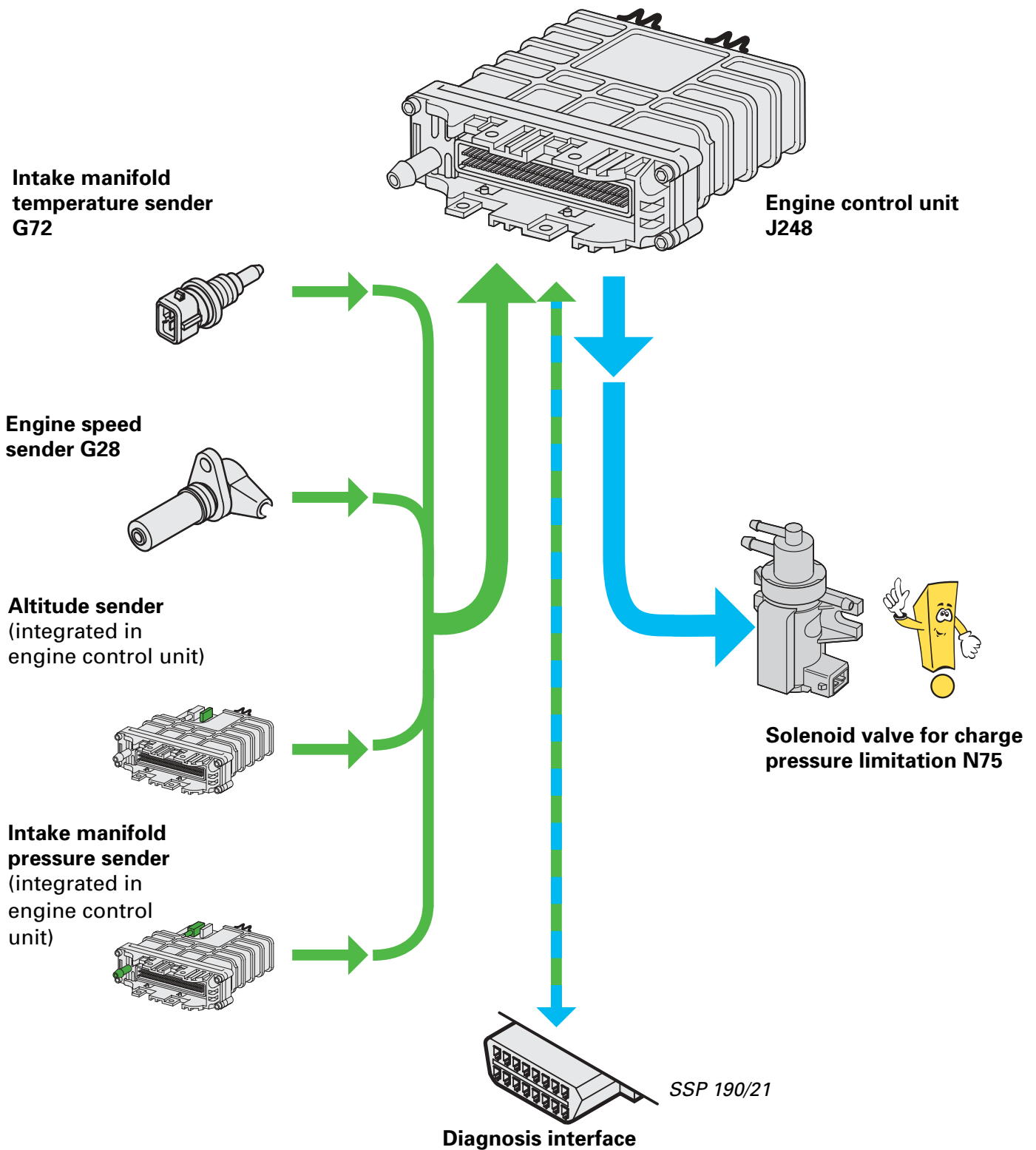

# Engine control unit

The adjustable turbocharger is controlled by the control unit of the engine on which the turbocharger is mounted.

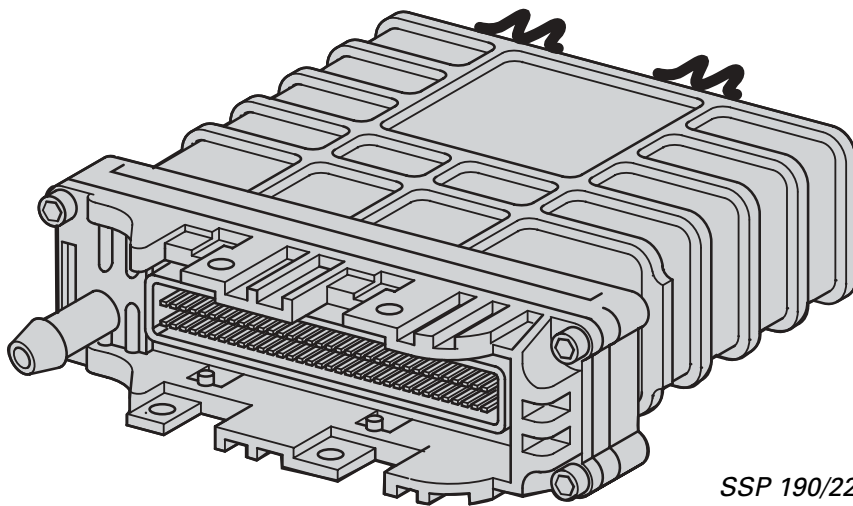

SSP 190/22

The new J248 engine control unit is equipped with a high-performance 16-bit micro-processor.

The high computing power of the engine control unit allows optimum charge pressure control by altering the pulse duty factor at solenoid valve N75.



The intake manifold pressure sender and the altitude sender do not have electrical abbreviations because they are integrated in the control unit.

# Sensors

## Charge pressure sender

The charge pressure sender is integrated in the engine control unit on the 1.9 ltr. TDI engine. It is connected to the intake manifold downstream of the turbocharger by way of a pressure pipe.

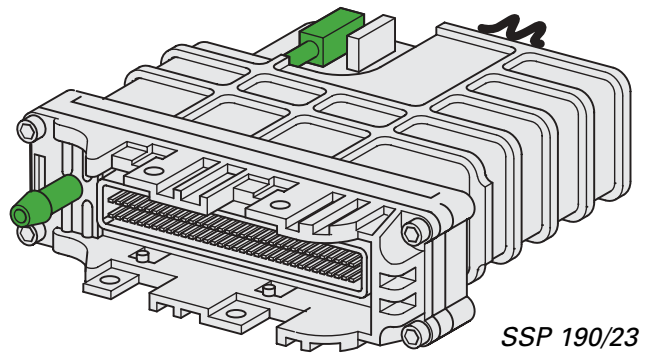

## Signal utilisation:

The charge pressure is required to calculate the vane angle adjustment.

## Effect of signal failure:

If the sender signal fails, the vanes are adjusted to a steep angle. Engine output is reduced.

## Fault message of self-diagnosis:

Control unit defective

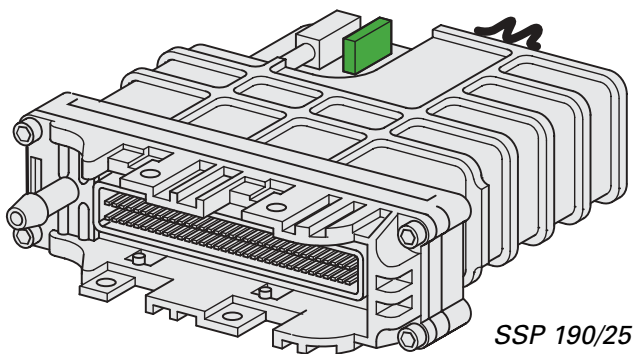

### **Altitude sender**

The altitude sender is integrated in the engine control unit. It signals the current ambient air pressure to the control unit.

### **Signal utilisation:**

The ambient air pressure is required as a correction value for charge pressure control since air density decreases with increasing altitude.

The signal is also used to control exhaust gas recirculation.

### **Effect of signal failure:**

If no signal is received from the altitude sender, the constant-output turbocharger is mapped.

This may lead to higher emissions and loss of power.

### **Fault message of self-diagnosis:**

Control unit defective

# Sensors

## Intake manifold temperature sender G72

The intake manifold temperature sender is inserted in the intake manifold downstream of the air intercooler.

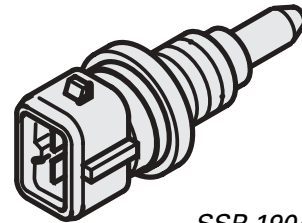

SSP 190/26

### Signal utilisation:

The intake manifold temperature is required as a correction value for charge pressure control.

It makes allowance for the effect of temperature on the charge air density.

### Effect of signal failure:

If the sender signal fails, the control unit uses a substitute temperature. This may lead to loss of power.

### Fault message self-diagnosis:

Short to earth  
Interruption/short to positive

### Electrical circuit

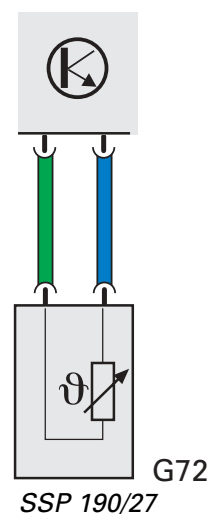



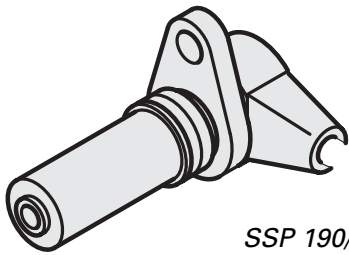

### Engine speed sender G28

This inductive sender registers the crankshaft speed

#### Signal utilisation:

The signal of the engine speed sender is needed to calculate numerous functions of the system control unit, such as:

- fuel injection quantity,
- injection point,
- idle control,
- charger control.

### Electrical circuit

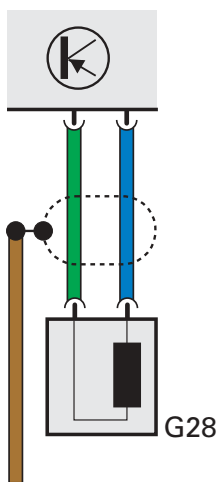

SSP 190/29

#### Effect of signal failure:

The engine cannot be started if no signal is received from the speed sender. If the fault occurs when the engine is running, the engine cuts out.

#### Fault message of self-diagnosis:

Plausibility of engine speed sender

# Actuators

## Solenoid valve for charge pressure limitation N75

Solenoid valve N 75 is controlled by the engine control unit. The vacuum in the low-pressure box is set by changing the signal clocks (pulse duty factor).

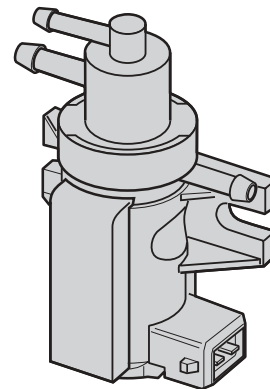

SSP 190/30

### Effect of signal failure:

The solenoid valve opens.  
This produces atmospheric pressure in the low-pressure box.  
This corresponds to the adjustment used in emergency operation.

### Fault message of self-diagnosis:

Short to positive  
Interruption/short to earth

### Electrical circuit

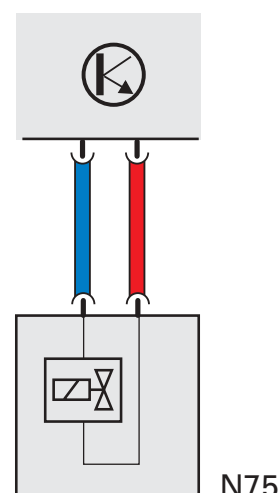

SSP 190/31

# Test your knowledge

**1. What is/are the effect(s) of altitude sender failure?**

- A  Charge pressure is too high
- B  Higher exhaust gas emission values
- C  Failure of the altitude sender has no effect.
- D  Fault message indicating defective control unit.

**2. Which of the following statements is correct?**

- A  If engine speed sender G28 fails, then the engine can no longer be started.
- B  If engine speed sender G28 fails, fuel consumption increases because the charger control is not functioning.

# Self-diagnosis

The engine control unit allows extensive self-diagnosis of all subsystems and components.

The diagnosis can be performed using the

- V.A.G 1551 and
- V.A.G 1552 fault readers.

To connect the diagnosis you require diagnosis cable

- V.A.G 1551/3

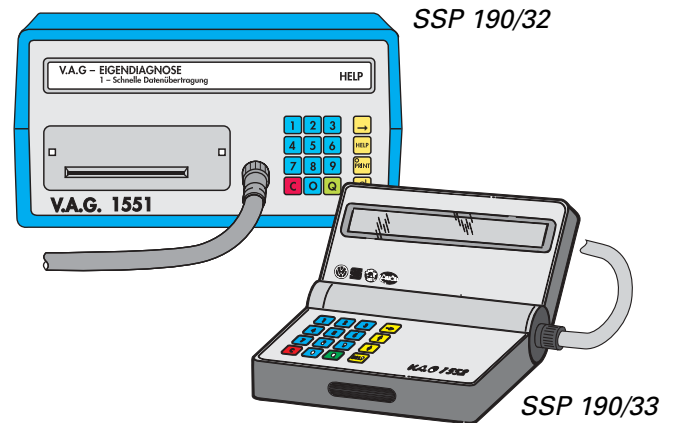

## The following functions are possible:

- 02 Interrogate fault memory
- 03 Actuator diagnosis
- 08 Read measured-value block
- 11 Charge pressure control

## Function 02 Interrogate fault memory

All senders/actuators are monitored by the self-diagnosis.

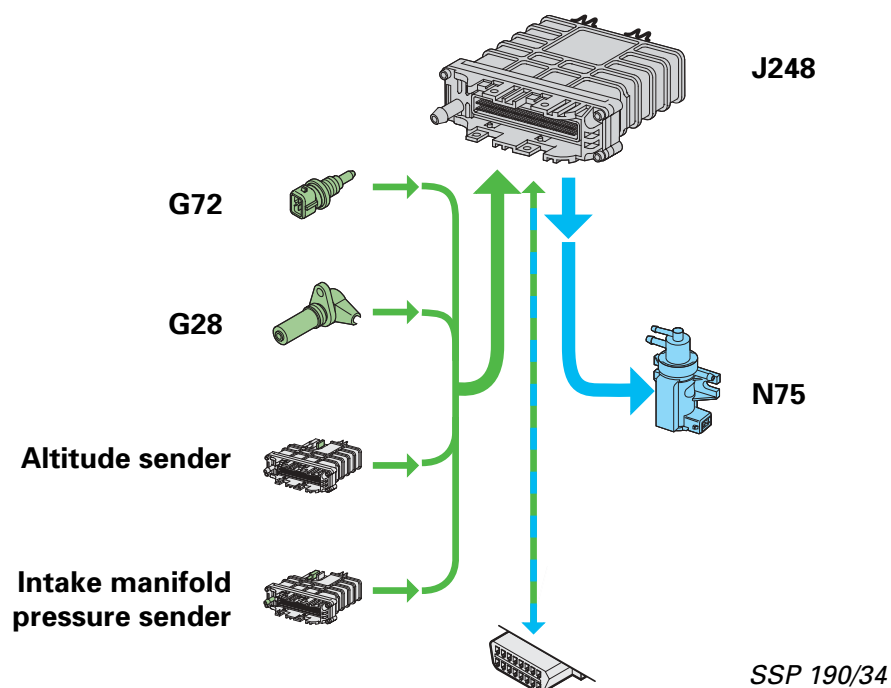

## Function 03 Actuator diagnosis

The colour-coded components are activated during the actuator diagnosis.

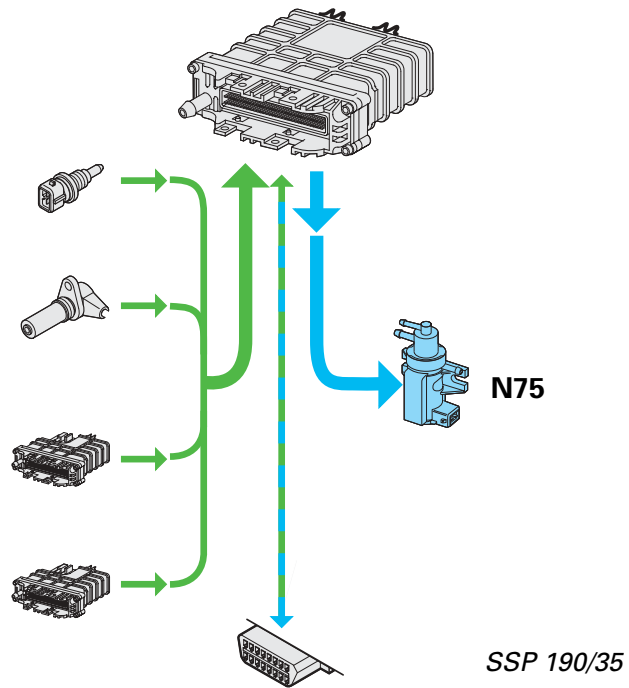

## Function 08 Read measured-value block

The colour-coded components are displayed in the measured-value block.

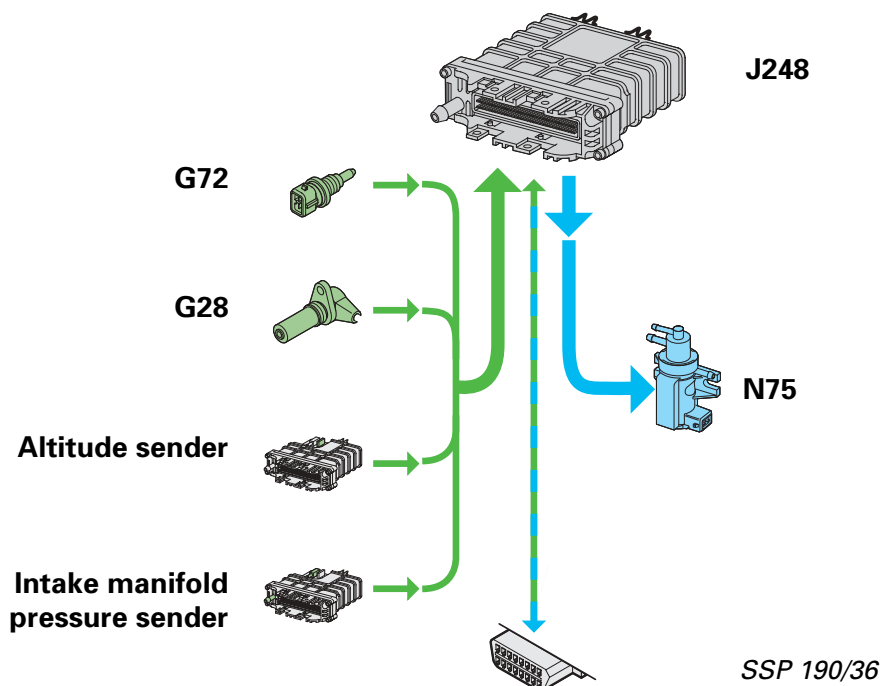

# Self-diagnosis

## Function 11 Charge pressure-control

The signals of the colour-coded components are required for monitoring the control unit.

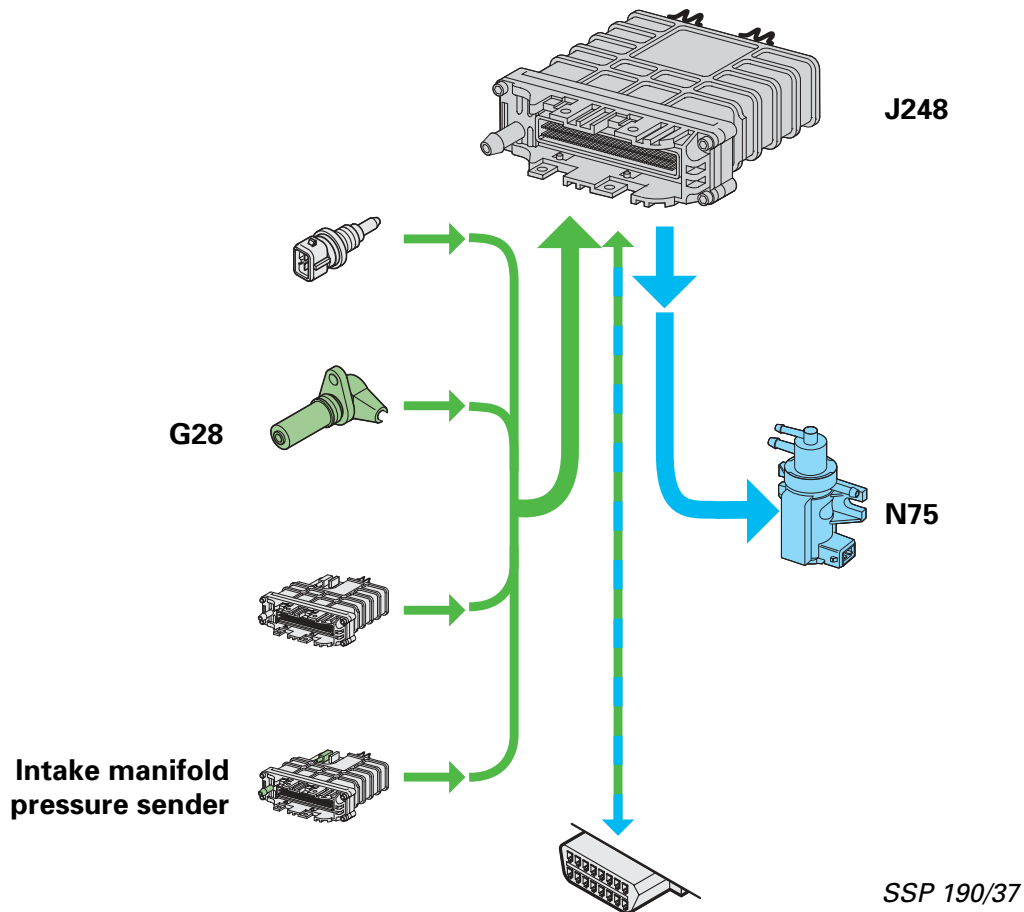

Display group number 11

Engine speed

Nom. charge pressure

Actual charge  
pressure value

Pulse duty factor of CPC

# Function diagram

## Components

G28 Engine speed sender  
G72 Intake air temperature sender

J248 Engine control unit  
J317 Voltage supply relay, terminal 30

N75 Solenoid valve for charge pressure limitation

The following senders are integrated in the control unit:

H Altitude sender  
G Intake manifold pressure sender

## Colour codes

- Input signal
- Output signal
- Positive
- Earth

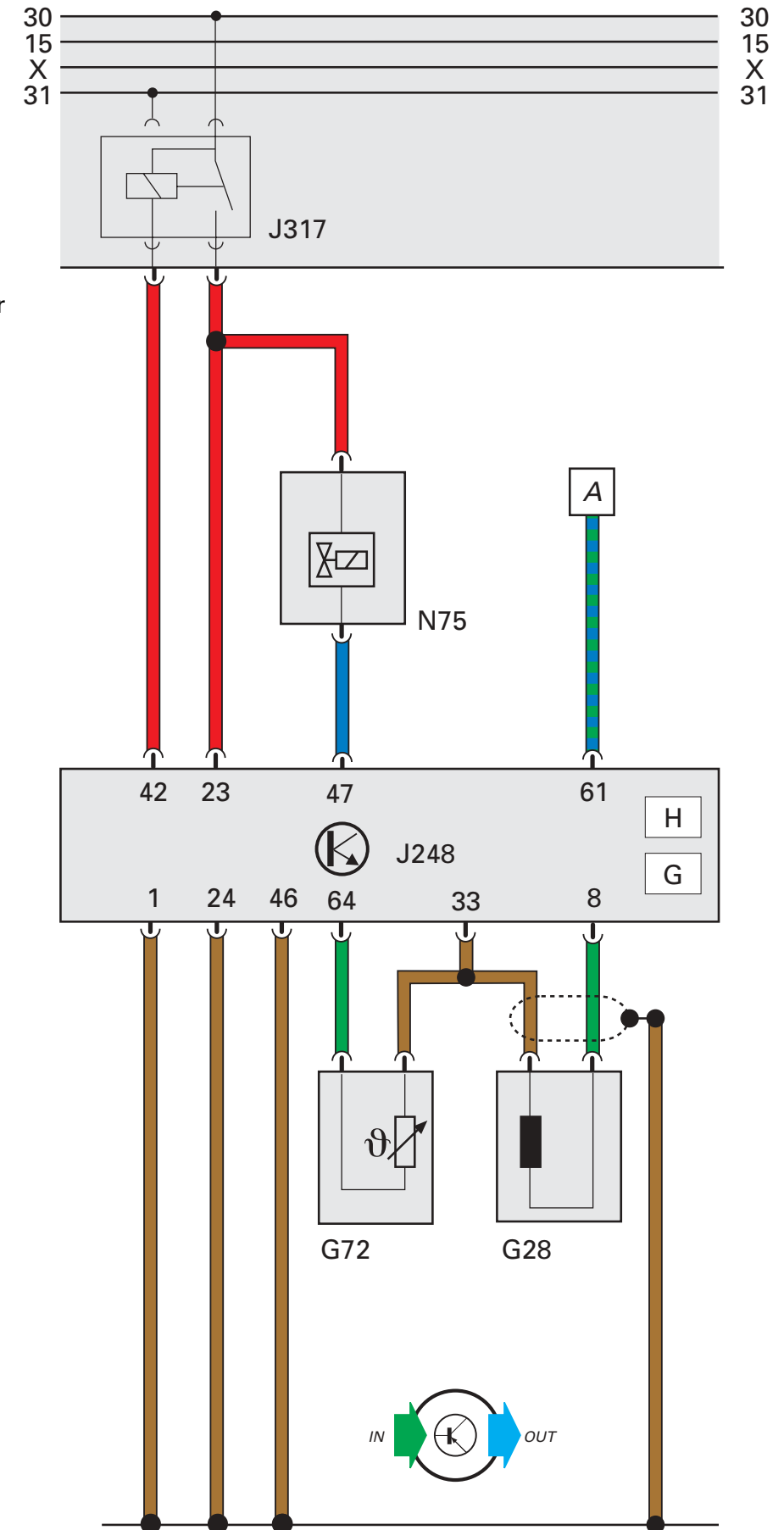

SSP 190/38



# Notes





